

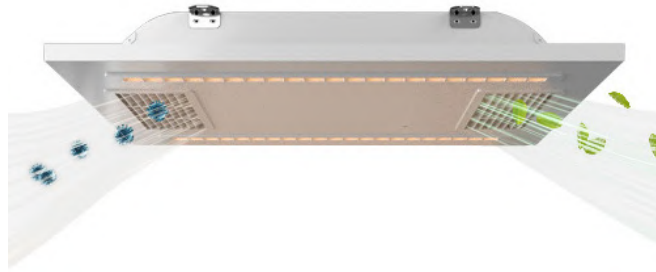

The UVC Collection

UVC-LP

UVC Light Panel - Anti-Bacterial Sterilization / Air-Circulating



DIMENSIONS

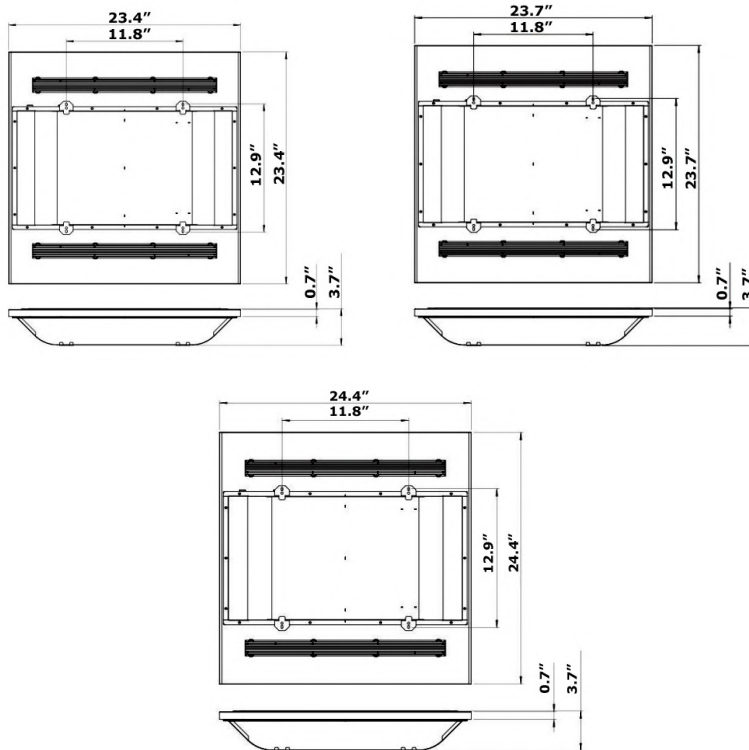

Catalog Number

Project Name & Location

Type

Product Specifications

COLOR TEMPERATURE: 3000K to 6000K Standard. 130LPW. CRI >80.

DRIVER: Universal Voltage 120-277V Electronic Driver.

FAN: 7.2W to power motorized fan. < 42db.

FILTER: G4 grade filter for inlet vent and medical grade filter for outlet vent.

FINISH: Painted White (WH).

HOUSING: Aluminum Housing.

LAMPING: Energy Efficient LED Engines - Non-Flickering / 4-Pin 254nm-99% UVC tube lamps.

MOUNTING: Lay-In Grid Recessed Mount is Standard. Optional Suspended Mount.

COMPLIANCE: CE / RoHS / SAA / CB / EPA Compliant. Indoor Use only.

WARRANTY: 5-Year Limited Warranty (Does not include UVC Lamp or Filters)

order example:

UVC-LP-L-LED30-CT4-UNV-WHT

SERIES

UVC-LP Ultraviolet-C Light Panel Series

SIZE

S 23.4" Sq. 3.7" Depth

M 23.7" Sq. 3.7" Depth

L 24.4" Sq. 3.7" Depth

LED WATTAGE

LED30 30 Watt LED

- 3600 Lumens (120 lm/W)

- UVC Wattage: 11W | 254nm

LED COLOR TEMPERATURE

CT3 ±3000K LED Color Temp

CT4 ±4000K LED Color Temp

CT6 ±6000K LED Color Temp

VOLTAGE

UNV 120-277 Universal Volt Electronic Driver

FINISH

WHT White

MOUNTING OPTIONS

SSPD Suspended Mount via Aircraft Cable

FEATURES & BENEFITS

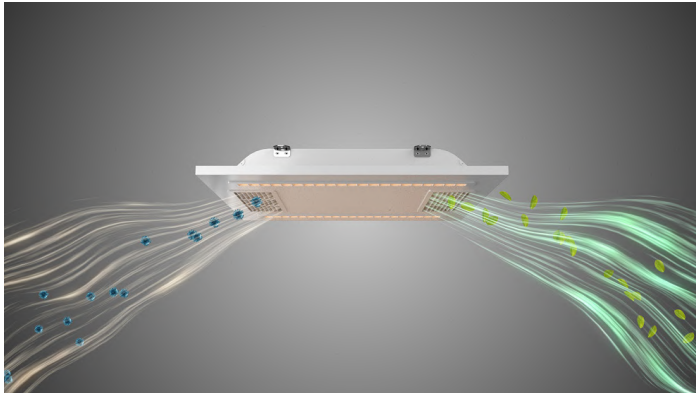

Air containing bacterial microbes and other harmful elements is drawn in through the inlet vent and clean filtered air is circulated back through the outlet vent.

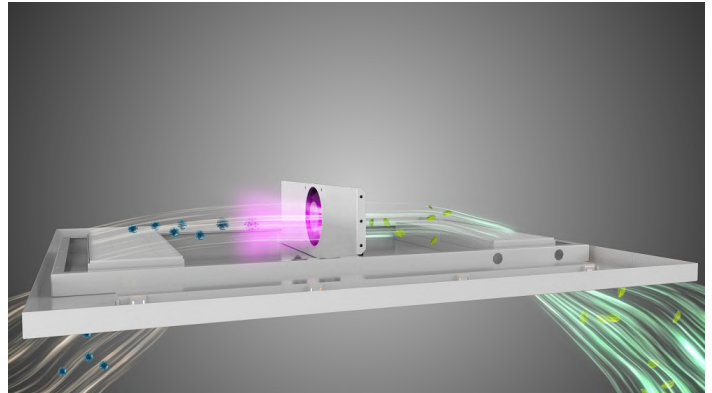

The built-in motorized fan and integral UVC lamp sterilizes and circulates the air at the same time providing a smooth and efficient means of air filtration and movement.



Included Remote Controller controls LED and UVC lamping.

Internal motorized fan and UVC lamping provides circulating airflow and sterilization.

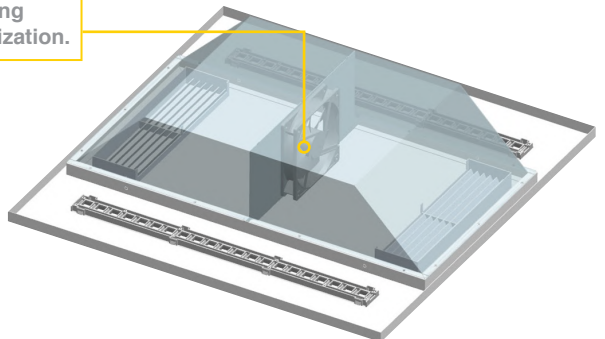

LED light engines provide reliable energy efficient illumination while air is being sterilized.

Inlet vent uses G4 grade filter to easily draw in air containing bacterial microbes and contaminants.

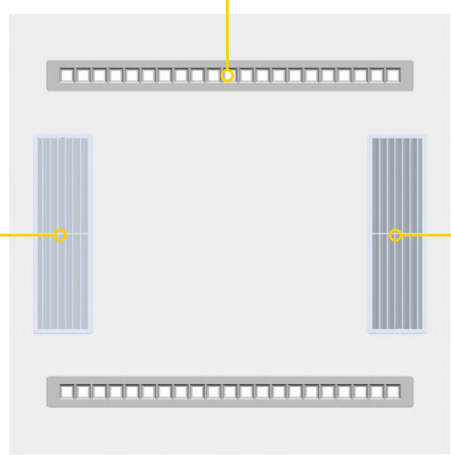

Outlet vent uses medical grade filter to capture any particles from the outgoing sterilized air.

REMOTE CONTROLLER FEATURES

Communication Type	Wireless Infrared
Controls	Separate Functions for Sterilization (UVC) / Lighting (LED)
UVC Time Settings	0.5H / 1H / 2H / 3H
LED Time Settings	1H / 2H
Batteries	2 x AAA

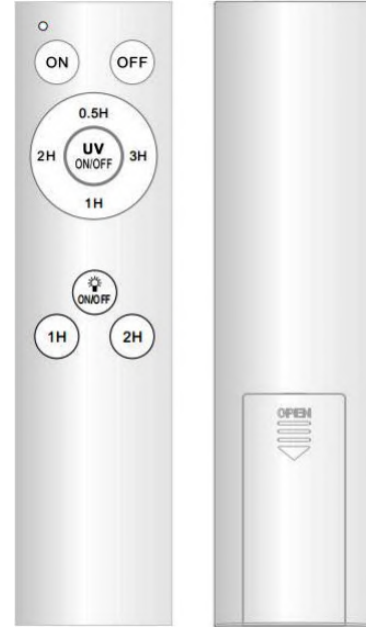

UVC LAMPING FEATURES

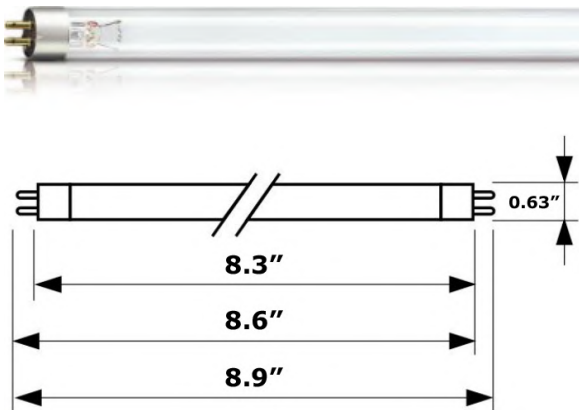

Spectral Wavelength

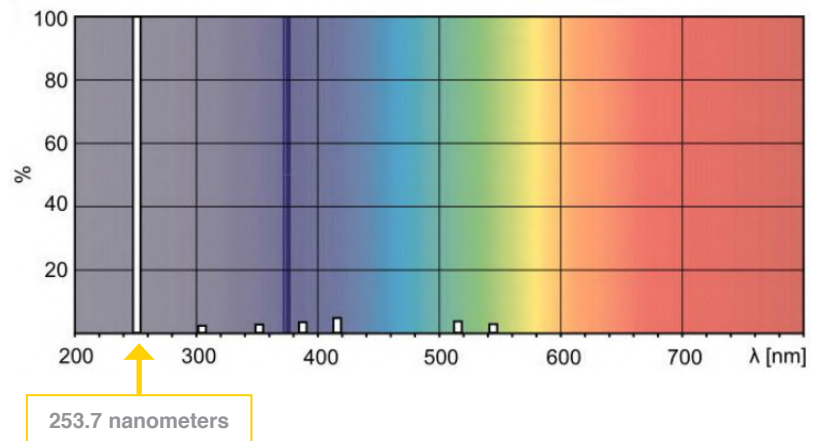

Lamp Base	G5
Application	Disinfection
Lifetime	11,000 Hours
Depreciation at Useful Lifetime	15% Depreciation (80% Efficiency at 9000 Hours)
SAFETY / WARNING DISCLAIMER	<ul style="list-style-type: none"> A lamp breaking is extremely unlikely to have any impact on your health. If a lamp breaks, ventilate the room for 30 minutes and remove the parts, preferably with gloves. Put them in a sealed plastic bag and take it to your local waste facilities for recycling. Do not use a vacuum cleaner. DANGER: Risk Group 3 Ultraviolet product. These lamps emit high-power UV radiation that can cause severe injury to skin and eyes. Avoid eye and skin exposure to unshielded product. Use only in an enclosed environment which shields users from the radiation.

TEST RESULTS - MICROORGANISM ANALYSIS

Contaminant	Action Time	Serial Number	Virus Levels in the Air (TCID50 /m³)	Disinfection Rate (%)
H1N1 Influenza Virus FM4.02 Host Name: MDCK Cell	1 Hour	Per-Test	9.50 x 10 ⁵	99.37
		After-Test	4.44 x 10 ³	
Contaminant	Action Time	Serial Number	Total Number of Bacteria in the Air (cfu /m³)	Disinfection Rate (%)
Escherichia Coli 8099	0(CK)	1	2.1 x 10 ⁶	N/A
		2	2.3 x 10 ⁶	N/A
		3	2.2 x 10 ⁶	N/A
Escherichia Coli 8099	2 Hour	1	9.1 x 10 ²	99.92
		2	9.1 x 10 ²	99.91
		3	9.1 x 10 ²	99.91
Staphylococcus Aureus ATCC 6538	0(CK)	1	2.1 x 10 ⁶	N/A
		2	2.3 x 10 ⁶	N/A
		3	2.1 x 10 ⁶	N/A
Staphylococcus Aureus ATCC 6538	2 Hour	1	9.1 x 10 ²	99.90
		2	9.1 x 10 ²	99.92
		3	9.1 x 10 ²	99.90
Contaminant	Action Time	Test Result Concentration Value of Blank Test Chamber (mg /m³)	Test Result Concentration Value of Sample Test Chamber (mg /m³)	Disinfection Rate (%)
Methanol	24 Hour	1.13	0.766	32.2
TVOC	24 Hour	5.98	4.89	18.2

PHOTOMETRIC DATA

Test Catalogue #: UVC-LP-LED30-CT4 Test Date: 12/15/2020								
Lamp Output	Lumen Efficacy	Input Voltage	Input Current	Input Wattage	Power Factor	Distribution Type	Color Temp	BUG Rating
3516.7 Lumens	121.9 LPW	230.7V	0.2784A	28.86W	0.902	Type VS	4000K	B2-U1-G1

Luminous Intensity Distribution Curve

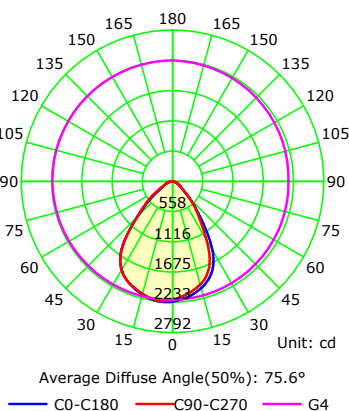

LCS Graph

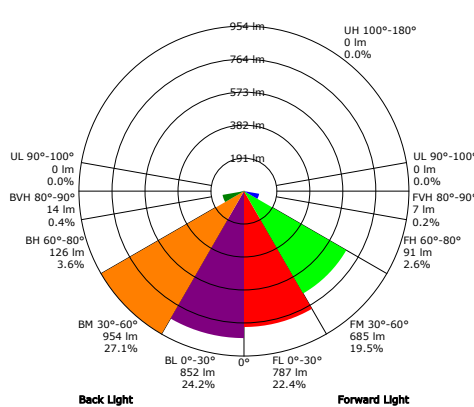

LCS Summary

Zone	Lumens
Forward Low (0-30)	787
Forward Medium (30-60)	685
Forward High (60-80)	91
Forward Very High (80-90)	7
Back Low (0-30)	852
Back Medium (30-60)	954
Back High (60-80)	126
Back Very High (80-90)	14
Up Low (90-100)	0
Up High (100-180)	0